

DEVELOPMENT BOARD

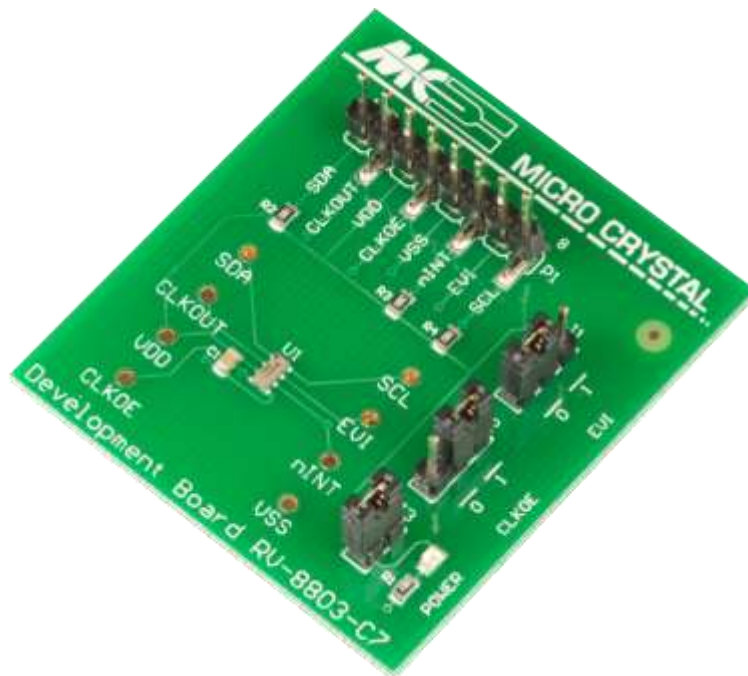

RV-8803-C7

Temperature Compensated Real Time Clock / Calendar Module

RV-8803-C7

The RV-8803-C7 is soldered onto the Development Board.
 Every pin is either accessible at test pins 1 – 8 or at the test vias situated around the device.

The following passive components are already soldered on the Board:

C1	10 nF	Decoupling capacitor between V_{SS} and V_{DD}
R1	330 Ω	Current limiting resistor for LED
LED	green	Supply, current consumption of the LED has to be considered
R2	10 k Ω	Pull-up resistor SDA to V_{DD}
R3	10 k Ω	Pull-up resistor INT to V_{DD}
R4	10 k Ω	Pull-up resistor SCL to V_{DD}

DEVELOPMENT BOARD

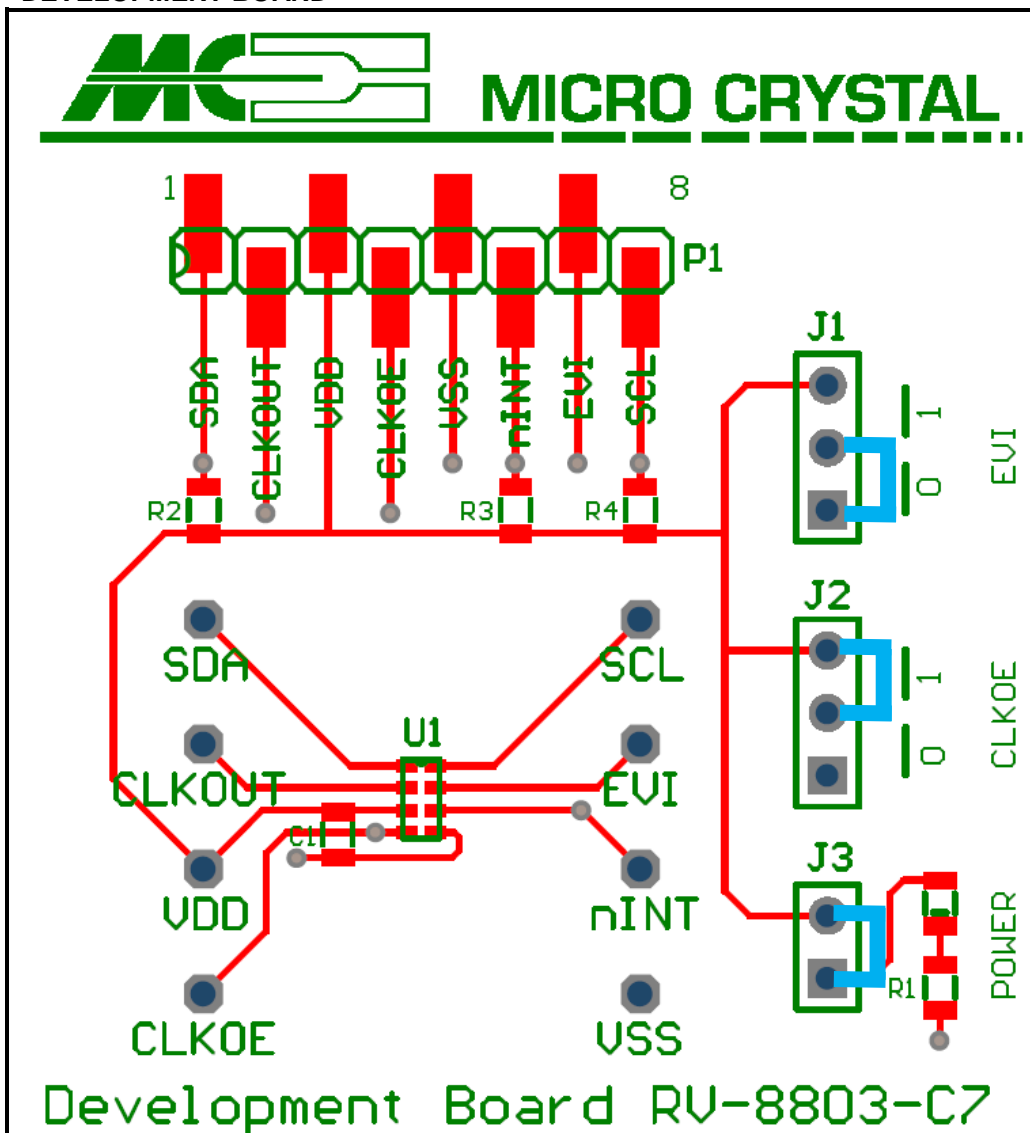

- JUMPER 1
- EVI = HIGH
- EVI = LOW
- JUMPER 2
- CLKOE = HIGH
- CLKOE = LOW
- JUMPER 3
- V_{BAT} = GND

SCHEMATICS

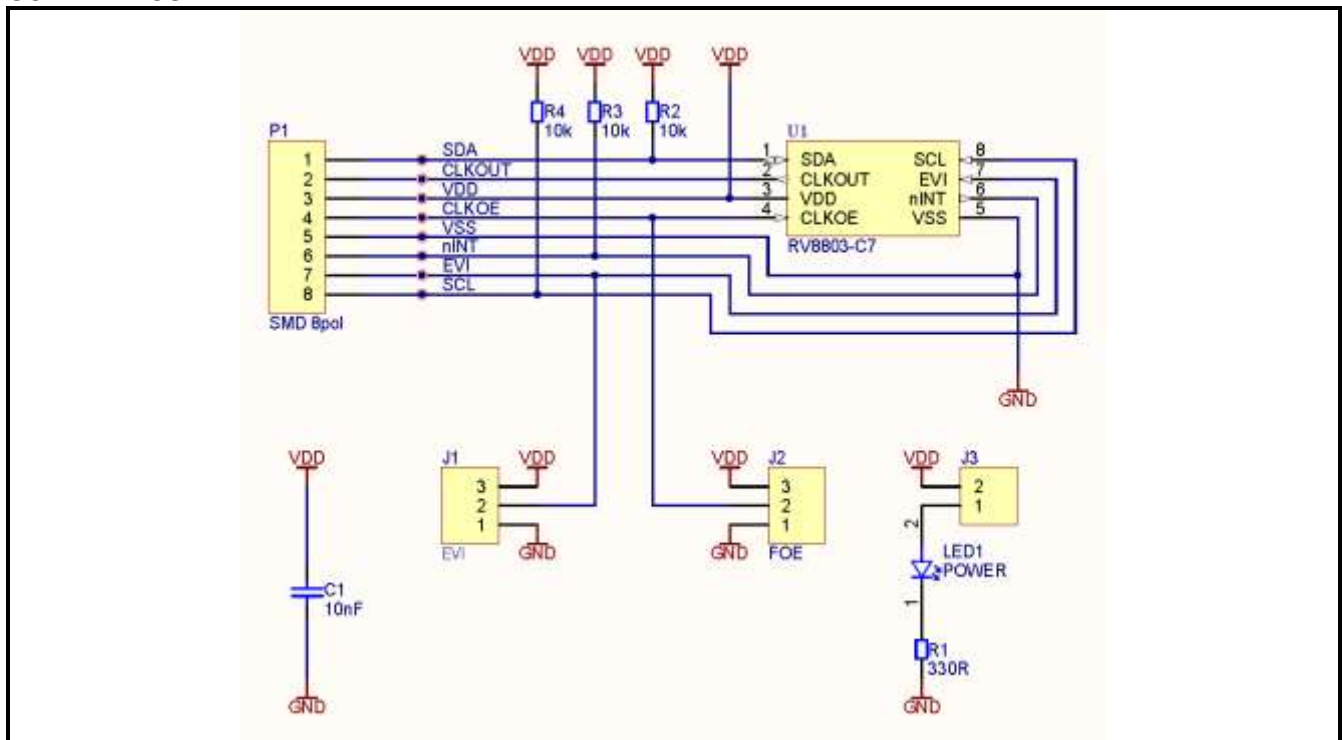

PINOUT RV-8803-C7

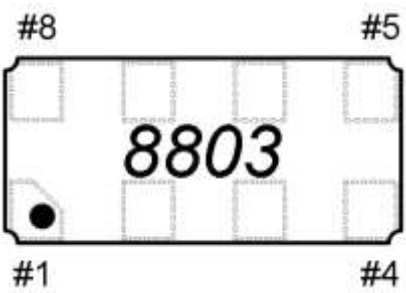

# 1	SDA	# 8	SCL
# 2	CLKOUT	# 7	EVI
# 3	V _{DD}	# 6	$\overline{\text{INT}}$
# 4	CLKOE	# 5	V _{SS}

PIN DESCRIPTION

Symbol	Pin #	Description
SDA	1	Serial Data Input-Output pin; open-drain; requires pull-up resistor
CLKOUT	2	Clock Output; push-pull; controlled by CLKOE. If CLKOE is active HIGH, the CLKOUT pin drives the square wave of 32.768 kHz, 1.024 kHz or 1 Hz (Default value is 32.768 kHz). When CLKOE is tied to Ground, the CLKOUT pin is high impedance (tri-state).
V _{DD}	3	Positive supply voltage; positive or negative steps in supply voltage may affect oscillator performance, recommend 10 nF decoupling capacitor close to the device
CLKOE	4	Input to enable the CLKOUT pin. If CLKOE is active HIGH, the CLKOUT pin is in output mode. When CLKOE is tied to Ground, the CLKOUT pin is stopped and is high impedance (tri-state).
V _{SS}	5	Ground
$\overline{\text{INT}}$	6	Interrupt Output; open-drain; requires pull-up resistor; Used to output Alarm, Periodic Countdown Timer, Periodic Time Update and External Event Interrupt signals.
EVI	7	External Event Interrupt Input.
SCL	8	I ² C Serial Clock Input; open-drain; requires pull-up resistor.

Datasheet and Application-Manual are available for download under: www.microcrystal.com